

Adjusting the Tachometer Pointer:

Use of the VDO Tachometer with an alternator almost always requires calibration of the pointer.

This can be done as shown in Diagram D. Please note that this calibration is designed to adjust the pointer reading between 30% and 100% of the RPM range.

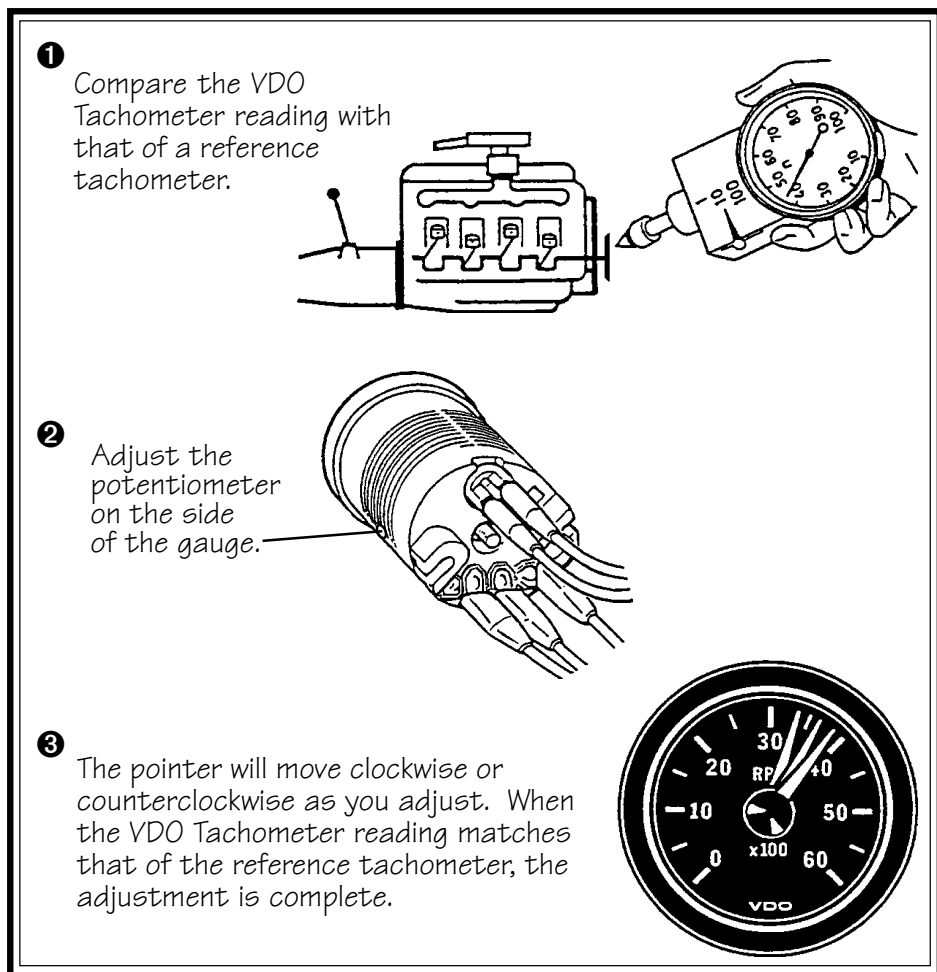

Diagram D

Fine adjustment needed when using the tachometer with an alternator

VDO Limited Warranty

VDO North America warrants all merchandise against defects in factory workmanship and materials for a period of 24 months after purchase. This warranty applies to the first retail purchaser and covers only those products exposed to normal use or service. Provisions of this warranty shall not apply to a VDO product used for a purpose for which it is not designed, or which has been altered in any way that would be detrimental to the performance or life of the product, or misapplication, misuse, negligence or accident. On any part or product found to be defective after examination by VDO North America, VDO North America will only repair or replace the merchandise through the original selling dealer or on a direct basis. VDO North America assumes no responsibility for diagnosis, removal and/or installation labor, loss of vehicle use, loss of time, inconvenience or any other consequential expenses. The warranties herein are in lieu of any other expressed or implied warranties, including any implied warranty of merchantability or fitness, and any other obligation on the part of VDO North America, or selling dealer.

(NOTE: This is a "Limited Warranty" as defined by the Magnuson-Moss Warranty Act of 1975.)

VDO North America • 188 Brooke Rd. • P.O. Box 2897 • Winchester, VA 22603 • Phone: 540-665-2428

If in doubt, please contact your dealer or VDO Instruments at (540) 665-2428.

CAUTION: Read these instructions thoroughly before making installation. Do not deviate from assembly or wiring instructions. Always disconnect battery ground before making any electrical connections.

CAUTION!!!

The bezel diameter is only a few millimeters larger than the gauge itself. Consequently, care must be taken when drilling hole for mounting of instrument.

Tools and Materials Needed For Installation:

16 Gauge stranded, insulated wire
Non-insulated ¼" spade connectors
2 ½" hole saw
Drill and drill bit set
Half-round file
Tape measure or ruler
Small tools: wrench or nut driver, utility knife, pliers, etc.

Tachometer Installation:

NOTE: If you will use your tachometer with an alternator, you must first wire it (Diagram C) and calibrate it (Diagram D) before mounting it. For all other applications, start here.

1. Select the location where you will mount the gauge, and cut a 2 ½" hole as shown in Diagram A.

2. Slip the VDO Spin-Lok™ Mounting Clamp over the back of the instrument. Direction of the clamp depends on the thickness of the panel (Diagram A). Tighten the clamp until the gauge can no longer be rotated by hand. **DO NOT OVERTIGHTEN.**

3. Wire your tachometer as shown in Diagram C.

[text continues] →

Parts List

Item	Description	Quantity
1.	Tachometer (2 ½" [52 mm] diameter)	1
2.	Lamp Socket (Push in, wedge-type)	1
3.	Light Bulb (12-volt / G.E. #158 or equivalent)	1
4.	VDO Spin-Lok™ Clamp	1
5.	Installation Instructions	1

VDO® North America

Tachometer Installation Instructions

Instruction Sheet # 0 515 012 044b
Rev. 02/01

INSTRUCTIONS FOR THE INSTALLATION OF THE TACHOMETER ARE CONTAINED HEREIN. USE IS RESTRICTED TO 12-VOLT NEGATIVE GROUND ELECTRICAL SYSTEMS. LIGHT BULB, IF SUPPLIED, IS 12 VOLT.

To Begin, go to # **1**

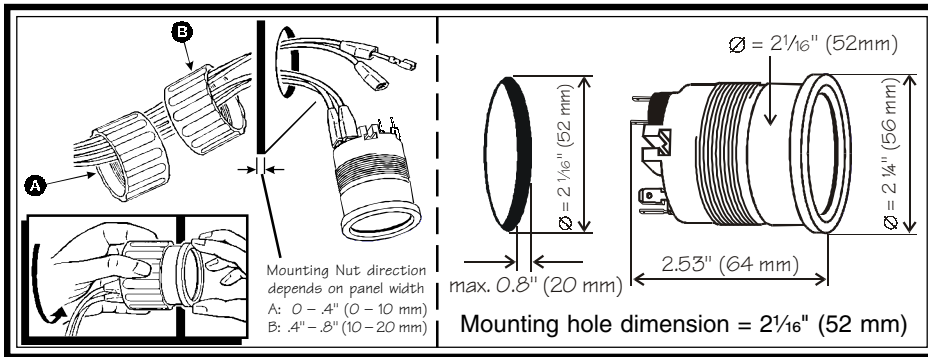

Diagram A
Gauge dimensions and mounting

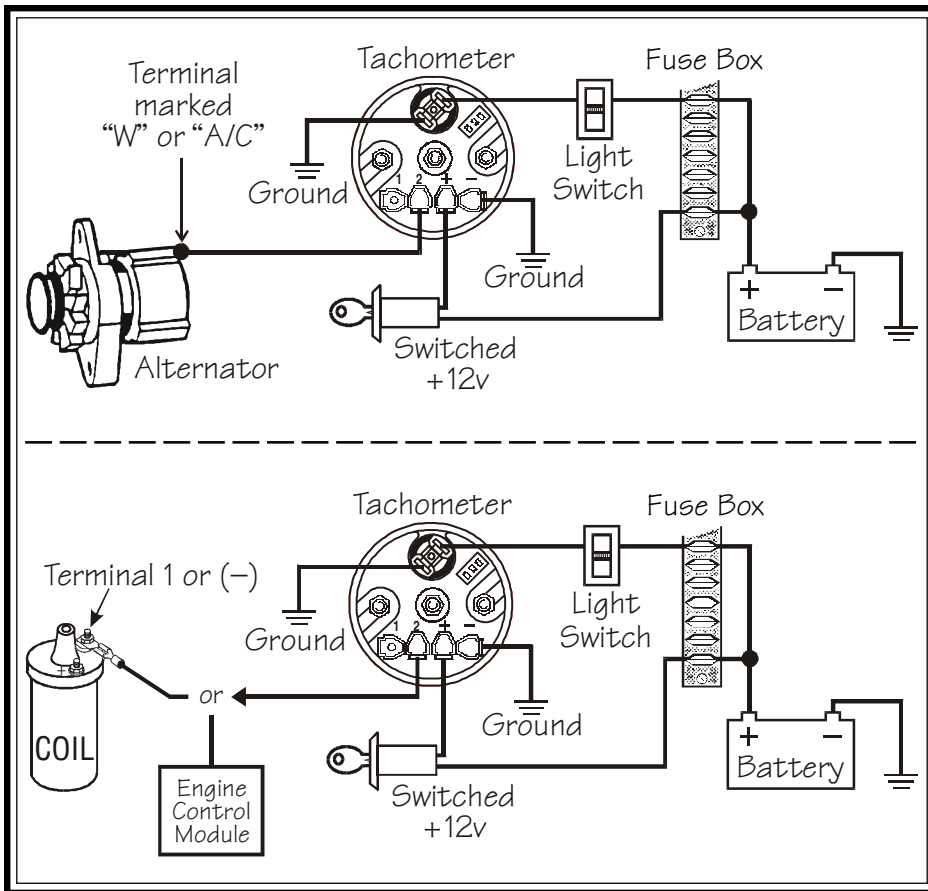

Diagram B
Tachometer wiring with Alternator (top); Ignition Coil or ECM (bottom)

Configuring the Tachometer:

Before your VDO Tachometer will function properly with your engine, you will need to configure it as described in the tables in Diagram C.

The table at the top of Diagram C shows

how to set the DIP switches for use with an ignition coil or an electronic ignition control box; the table at the bottom shows how to set the DIP switches when using the tachometer with an the A/C tap on an alternator. See Diagram D for fine tuning the tachometer when used with an alternator.

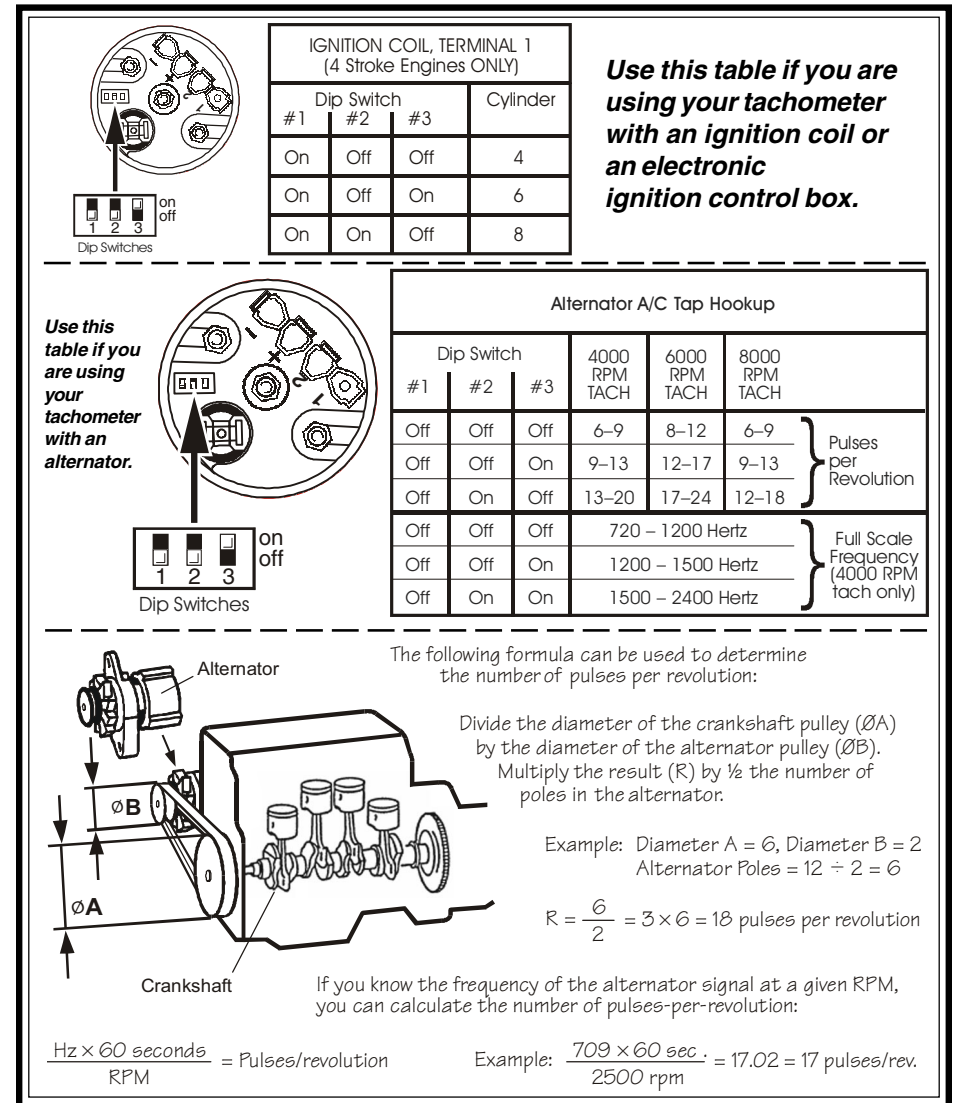

Diagram C
Tachometer configuration for use with ignition coil (top table) or alternator (bottom table); use formulas to calculate pulses-per-revolution